

contrec

Batch Controller

Model 214D



Features

- Displays Batch Total, Accumulated Total and Preset
- One or two stage valve control
- ATEX Class 1, Zone 1 approved
- CSA_{US/C} Class 1, Groups C & D approved
- Watertight to IP67 (Nema 4X)
- Wall or pipe mounting
- Fully programmable
- CE compliant



Overview

The Model 214D Batch Controller is designed for flow applications where the precise control of batch quantities is required. Batch Total, Accumulated Total and Preset values can all be displayed on the large LCD display.

For hazardous area applications, the 214Di is an intrinsically safe version with both ATEX approval, and CSA approval covering both the USA and Canada.

The 214D has an input conditioning circuit which will accept pulse or frequency flow signals generated by turbine, positive displacement, paddlewheel or other flowmeters.

Configurable link positions enable the input circuit to be configured for the different signal types.

DC powered with battery backup

The 214D will operate from an external power source between 9 and 28 Volts and draws no more than 4mA.

Lithium batteries provide backup if the DC power is interrupted so that totals are not lost. The solenoids or sensors, however, may still require external power.

Solid state outputs provide control to solenoids and relays, and can sink up to 200mA.



Accuracy • Quality • Performance

Model 214D

Batch Controller

Watertight field mounting enclosure

The 214D Rate Totaliser is housed in a rugged yet attractive IP67 (Nema 4X) rated polycarbonate enclosure which is completely watertight.

A special universal bracket, supplied as standard, enables the instrument to be wall mounted. A 2" pipe mounting bracket is also available as are bottom and rear mounting stems for mounting the 214D directly on turbine flowmeters which have a 1" NPT or BSP boss.

Fully user programmable

K-factor, decimal point positions, valve delays and signal timeouts are fully user programmable.

The Signal Timeout feature, if programmed, will automatically stop the batch if the flow signal cuts out midway through a batch.

One or two stage valve control

Two solid state relays are provided which can be set up to control a single or a two stage valve with slow stop and/or slow start. Alternatively, the second output can be used to control a pump.

The first output will energise at the start of the batch, and de-energise when the batch is complete.

The second output can be programmed to energise at a delayed Start Time after the batch start (0 to 9 seconds delay), and to de-energise at a Prestop quantity prior to completion of the batch. This feature enables a slow startup and slow shutdown of the flow.

Keyboard Operation

The unique 3 key operation of the 214D simplifies operation and enables batches to be controlled quickly and efficiently.

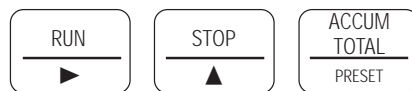

214D Facia

To enter a batch, the PRESET key is pressed and the ▲ and ► keys can be used to increment and change digits. Once set, the PRESET key is pressed again to return to the run mode.

In the run mode, the RUN and STOP keys are used to start, stop or to pause the batch.

Intrinsically Safe Installation

The 214Di is certified for use in hazardous areas with approved sensors and solenoids, according to the following approvals.

ATEX

Approval: DMT 03 ATEX E 097

Type of Protection: II 2G EEx ia IIB T3

CSA_{US/c}

Approval: 104840-5

Locations: Class 1, Groups C & D

Temperature: Maximum ambient of 60°C

Flowmeter Input

The 214Di will connect directly to a turbine or paddlewheel with a certified IS coil or other certified IS devices which produce a pulse output, provided they do not produce a voltage, current or power which exceeds:

$$U_i = 24V, I_i = 20mA, P_i = 320mW$$

The maximum allowed capacitance and inductance of the pulser or coil, including cabling is limited to:

$$C_{ext} = 60\mu F, L_{ext} = 1.5H$$

Output parameters on the input are:

$$U_o = 10.0V, I_o = 9.0mA$$

Note that devices such as reed switches, which can be classed as "Simple Apparatus" as defined in EN50020, may be connected to the 214Di without additional certification.

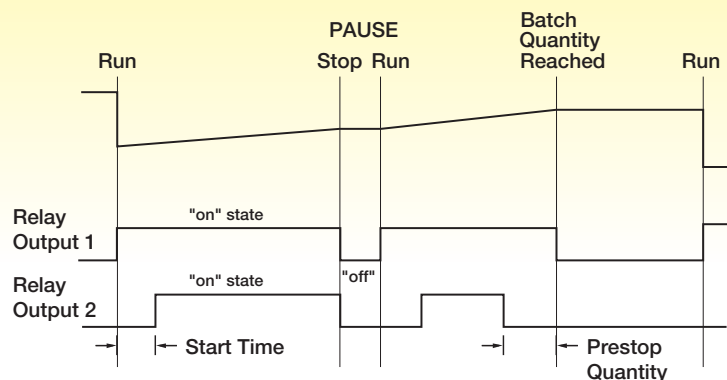

Two Stage Valve Control



Flowmeters with Namur Proximity switches

Namur Proximity switches may be used but will require a separate barrier to power the Namur switch, as shown opposite.

Output and DC power

A barrier is required to provide DC power to the instrument and to power the IS solenoids or relays. One or two barriers may be used depending upon whether a one or two stage valve is used. Connection is as shown opposite.

Only certified intrinsically safe solenoids may be used for IS applications. Because these solenoids have a relatively small coil, they are usually only suitable for small line sizes and non-viscous products.

Generally, it is preferable to use a pneumatic system with the solenoid valves controlling air to a larger pneumatically controlled valve.

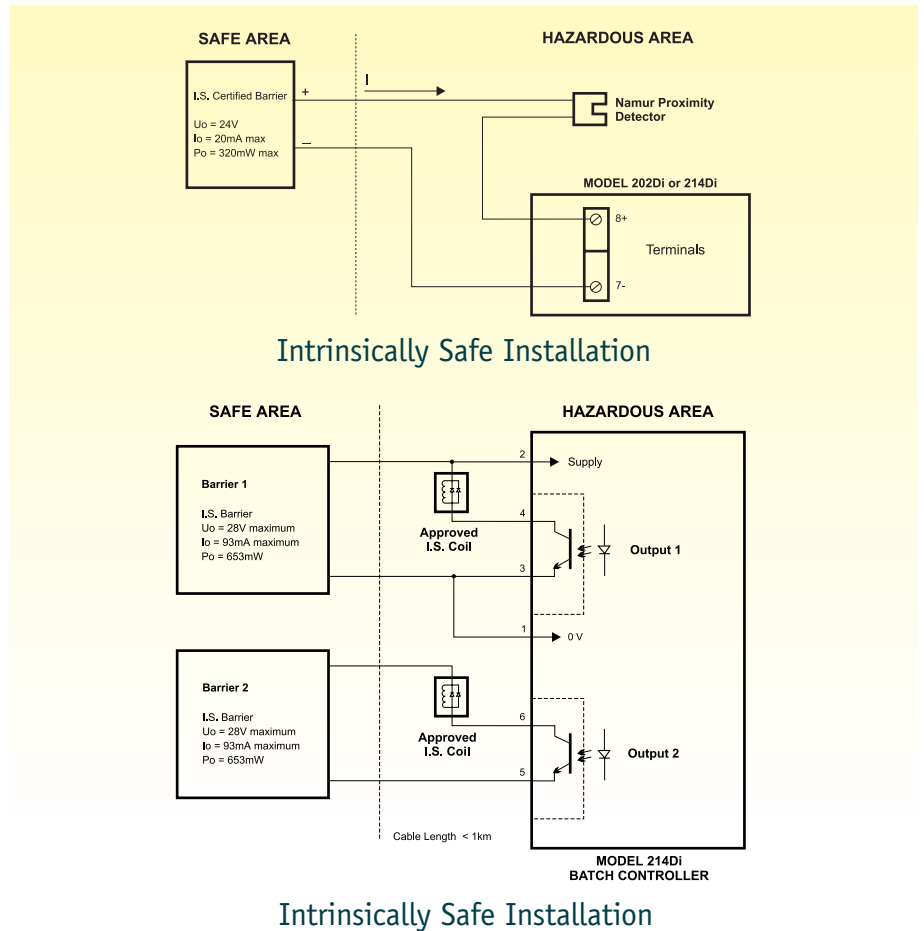

Dimensional Diagrams

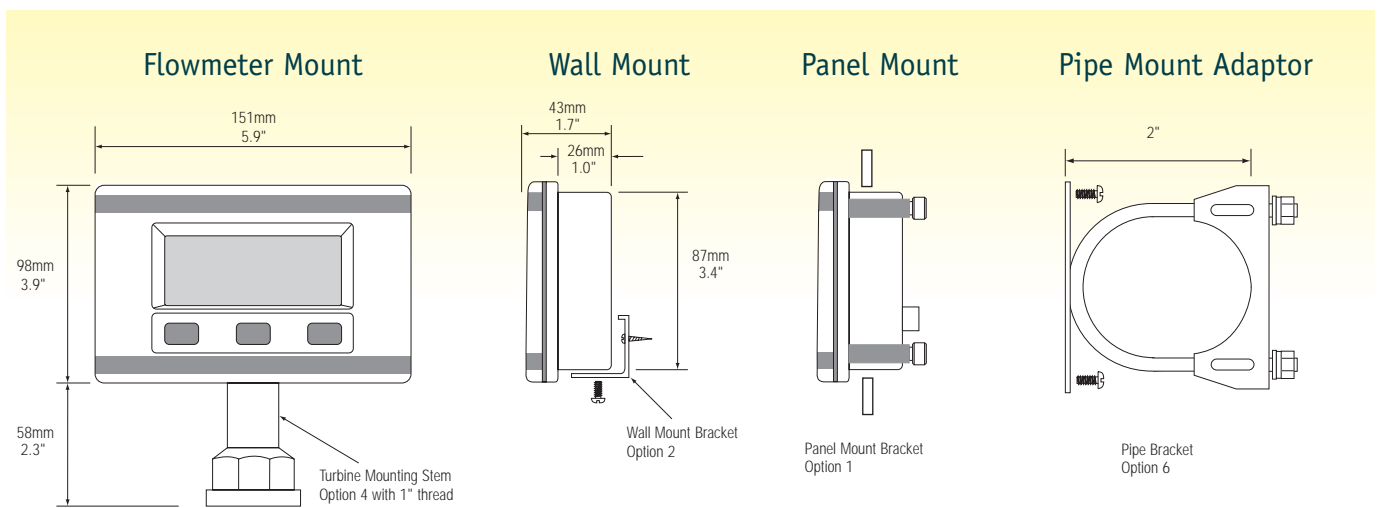



Specifications

General

Display

Batch Total: 7 digit 10mm (0.4") high LCD (continuously powered).

Note: The Accumulated Total is displayed when the ACCUM TOT key is pressed.

Preset: 5 digit 8.5mm (0.33") high LCD (continuously powered).

K-factor Range: The pulses per unit of measure (eg. pulses/gallon) is programmable in the range of 0.0001 to 999,999.

Decimal Points: Fully programmable for Total.

Frequency Range: 0Hz to 10kHz.

Signal Type: Link settable for sine wave (15mV P-P minimum), open collector, reed switch or pulse.

Interference: CE compliance.

DC Power Input: 9-28V @ 4mA maximum.

Physical

Operating Temperature: -20 to 60°C.

Enclosure

Protection: IP67 (Nema 4X) watertight.

Cable Entry: By cable glands.

Materials: Polycarbonate and ABS.

Mounting Options

Wall: Wall mount bracket.

Pipe: A galvanised metal bracket enables the 214D to be attached to a 2" vertical or horizontal pipe.

Panel: Two mounting brackets supplied.

Turbine Meter: Bottom and rear mounting stems are available for mounting the 214D directly on turbine flowmeters which have a 1" NPT or BSP boss.

Battery Backup

Type: 2 x Lithium battery packs.

Function: The batteries will provide backup power for the instrument if no DC power is available. The batteries will not power the sensor (if power is required) or solenoid outputs.

Outputs

Type: 2 x solid state relay outputs suitable for driving DC solenoids or external relays. The outputs provide for one or two stage control of the flow.

Switching Power: 200mA, 30V dc maximum.

Saturation Voltage: 0.8V dc across outputs when in the "on" state.

Isolation: Both outputs are separately isolated.

Terminal Descriptions

Number		Number	
1	DC Power Input 0V	5	Output 2 (-)
2	DC Power Input 9-28V	6	Output 2 (+)
3	Output 1 (-)	7	Pulse/Coil Input (-)
4	Output 1 (+)	8	Pulse/Coil Input (+)

Product Codes

Product Codes

214D	.	3	Batch Controller
Intrinsic Safety	i		Intrinsically safe Not intrinsically safe
Enclosure and Mounting	0 1 2 3 4 5 6		Wall Mounting (no gland holes) Panel Mount Wall Mounting (Standard glands) Explosionproof Enclosure (USA Only) Turbine Mount (bottom) Turbine Mount (rear) Pipe Mount
Output (Standard)		3	DC Powered
Hazardous Approvals		C M S	CSA US & Canadian Approval ATEX Approval SAA Australian Approval No Approvals

Typical Part Numbers: 214Di.23M or 214D.13

Important: Specifications are subject to change without notice.

www.contrec.com.au

Contrec Pty. Ltd.

22 Hall Street, Hawthorn East
Melbourne 3123 AUSTRALIA

Tel: +61 3 9804 4200 Fax: +61 3 9822 8329

Email: sales@contrec.com.au

Contrec Europe Limited

PO Box 436 Sowerby Bridge
West Yorkshire HX6 3YA, UK

Tel: +44 1422 829 940 Fax: +44 1422 829 941

Email: sales@contrec.co.uk

Contrec - USA, LLC

916 Belcher Drive, Pelham AL 35124 USA

Tel: (205) 685 3000 Fax: (205) 685 3001

Email: contrec@contrec-usa.com